

FLUSH MOUNTED

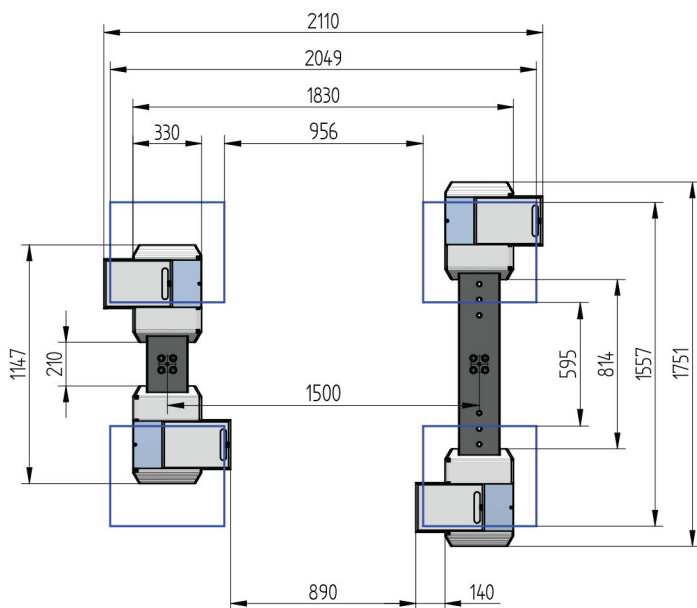
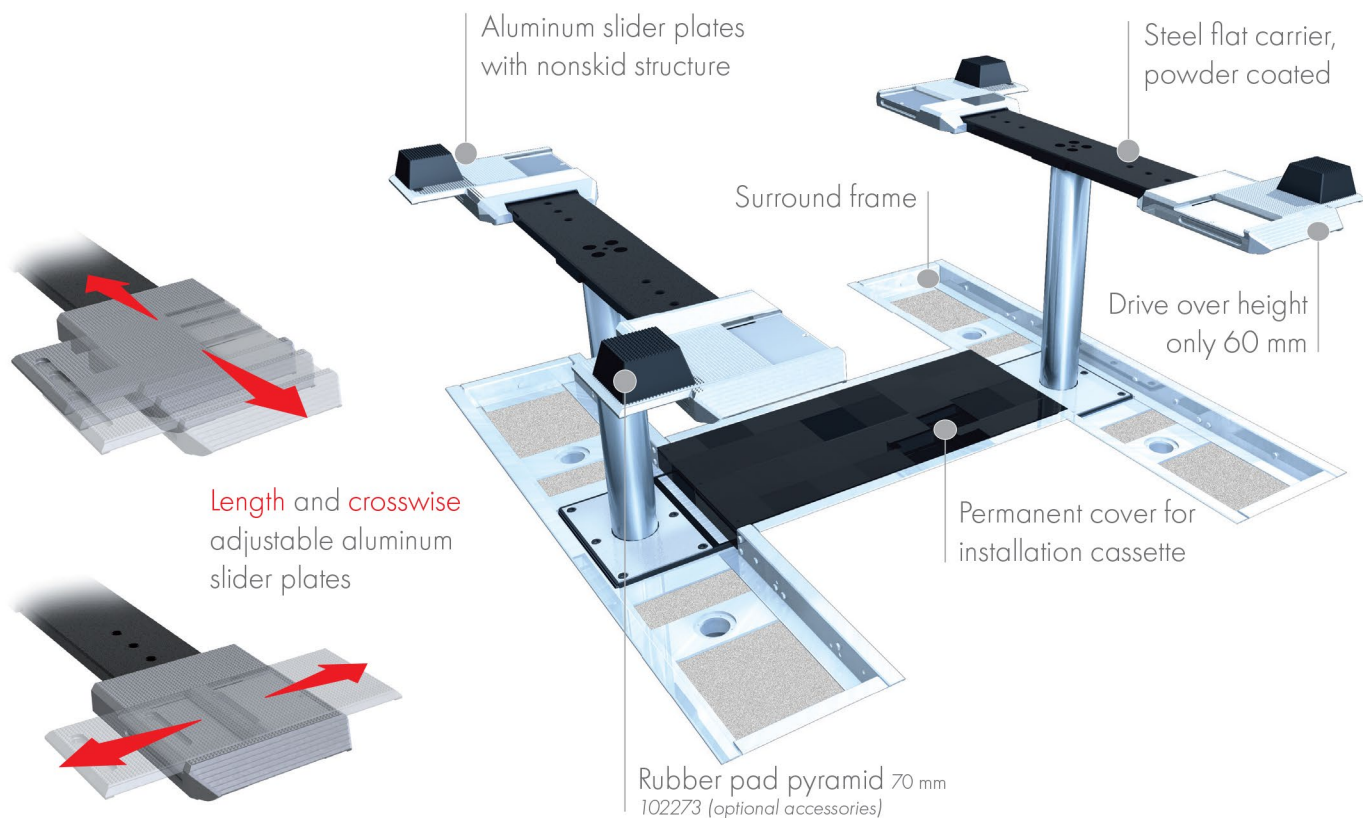

TECHNICAL DATA

Capacity	3500 kg
Drive over height	60 mm
Piston diameter	123 mm
Piston distance	1500 mm
Motor output	3,0 kW
Power connector	400 V/16 A
Cable length to control	11 m
Lifting time	≈ 35 sec.
Lowering time	≈ 35 sec.

Support Uni 2.35 plus midi	102646
Support Uni 2.35 plus midi galvanized	105224
Installation cassette STEEL 1500 mm	2260XX
Installation cassette STEEL 1500 mm galvanized	2261XX
Lifting unit oil 3,5 t 1500 mm - K pre-assembled in installation cassette	109965
Lifting unit oil 3,5 t 1500 mm - H packed in wooden box	109977
Surround frame Uni plus mini 1500	113019



ACCESSORIES

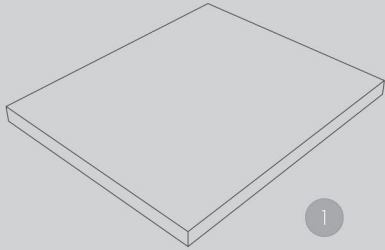

1

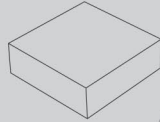

2

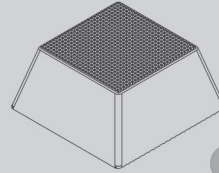

3

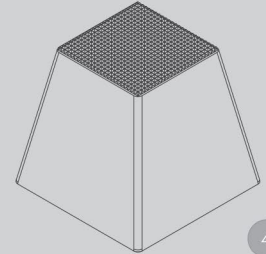

4

1 Rubber pad
290 x 335 x 20 mm
102275 (1 Set / 4 Pieces)

2 Rubber pad
120 x 120 x 40 mm
102274 (1 Set / 4 Pieces)

3 Rubber pad pyramid
70 mm
102273 (1 Set / 4 Pieces)

4 Rubber pad pyramid
140 mm
102291 (1 Set / 4 Pieces)

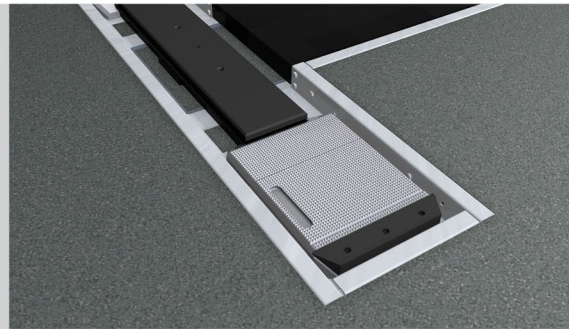
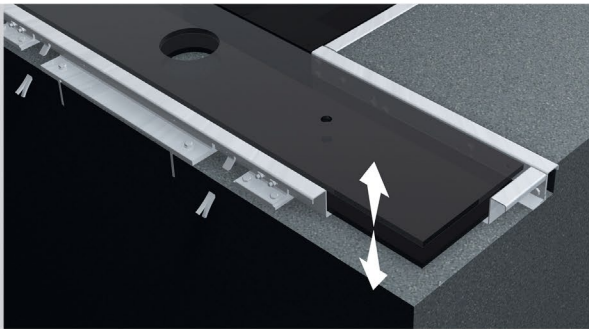

Floor compensation Uni plus mini
powder coated
112330

Levelling plates Uni plus mini
for flat surface of the carriers
110338 (1 Set / 2 Pieces)

Levelling wedges Uni plus
for flat surface of the slider plates
109605 (1 Set / 2 Pieces)